

NOTES:

- Max. angle 115°
- Operating temperature -5 ~ 50°C
- Weight 10.5±1g
- Body and cap material Polybutylene terephthalate (PBT)
- Rotating shaft material Polybutylene terephthalate (PBT)
- Oil type Silicone oil
- Contact sales office for tolerances

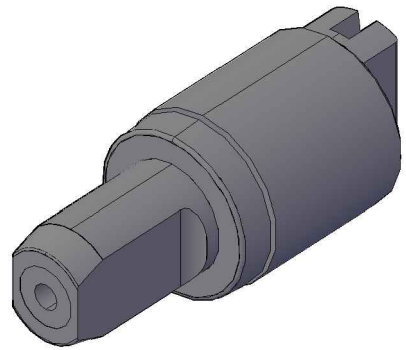

PART NUMBER	ROTATION	TORQUE	RETURN TORQUE	COLOUR
43009-RH-10	CLOCKWISE	1 N-m (10kgf-cm)	0.3N-m (3kgf-cm)	BLACK
43009-LH-10	COUNTER-CLOCKWISE	1 N-m (10kgf-cm)	0.3N-m (3kgf-cm)	BLACK WITH GREY ROTATING SHAFT
43009-RH-15	CLOCKWISE	1.5 N-m (15kgf-cm)	0.5N-m (5kgf-cm)	BLACK
43009-LH-15	COUNTER-CLOCKWISE	1.5 N-m (15kgf-cm)	0.5N-m (5kgf-cm)	BLACK WITH GREY ROTATING SHAFT
43009-RH-18	CLOCKWISE	1.8 N-m (18kgf-cm)	0.8N-m (8kgf-cm)	BLACK
43009-LH-18	COUNTER-CLOCKWISE	1.8 N-m (18kgf-cm)	0.8N-m (8kgf-cm)	BLACK WITH GREY ROTATING SHAFT

ISSUE	DATE	SIG	REMARKS

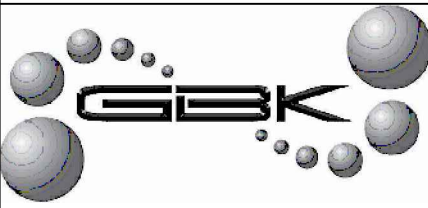

email: info@gbk-uk.com
web: www.gbk-uk.com

TOLERANCES
 X 0.50
 X.X 0.25
 X.XX 0.10
 ANGLES 0.25°
 UNLESS OTHERWISE STATED

ALL DIMENSIONS IN mm

THIRD ANGLE PROJECTION

DO NOT SCALE FROM DRAWING,
IF IN DOUBT PLEASE ASK!

MATERIAL	See notes
COLOUR	See notes
SCALE	2:1 @ A4
DRAWN	BK
DATE	21.11.12
SHEET	1 of 1

© GBK UK Limited
 THESE DRAWINGS AND THE SPECIFICATIONS, AND THE DATA CONTAINED THEREIN ARE THE PROPERTY OF GBK UK LIMITED, ISSUED IN STRICT CONFIDENCE AND SHALL NOT WITHOUT PRIOR WRITTEN PERMISSION OF GBK UK LIMITED BE PRODUCED, COPIED OR USED FOR ANY PURPOSE WHATSOEVER, EXCEPT THE MANUFACTURE OR ARTICLES FOR GBK UK LIMITED.

DESCRIPTION	DRAWING No.
Barrel Damper	43009